

(All components designed and manufactured by Stewarts)

## Trunnion style

The trunnion design allows it to be secured in position with composite bearings, assuring a very strict relationship between the trunnion and seat. As a result the trunnion style valve has few limitations on pressure ratings.

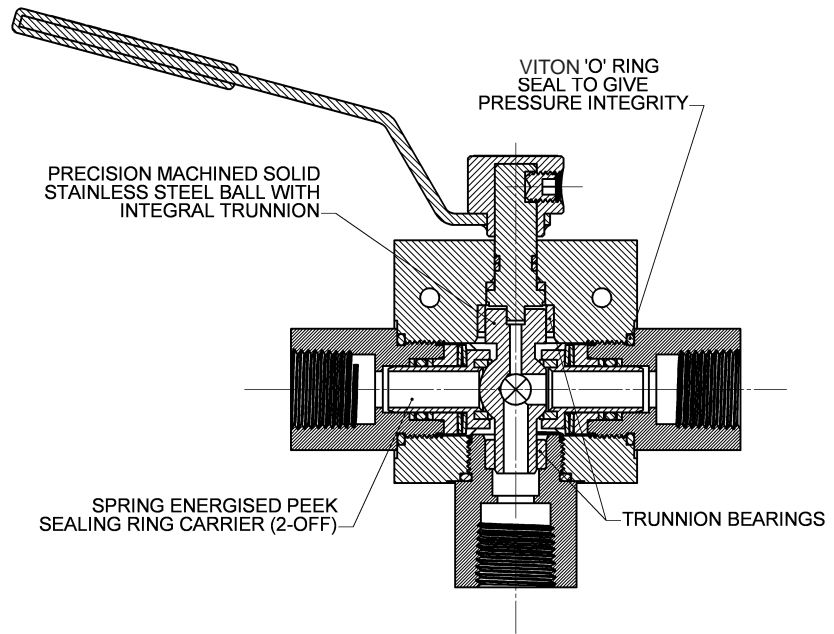

## OTHER FEATURES

- Hydrostatically tested to 1.5 times maximum working pressure.
- Available in a variety of materials, AISI 316 stainless steel, Monel etc.
- Has trace code on body and end connectors with material certificates available for all wetted parts on request.
- Can be supplied to NACE MR-01-75.
- Other seals available by arrangement.
- 90 Deg turn precision ball with integral trunnion.

## PRESSURE / TEMPERATURE RATINGS

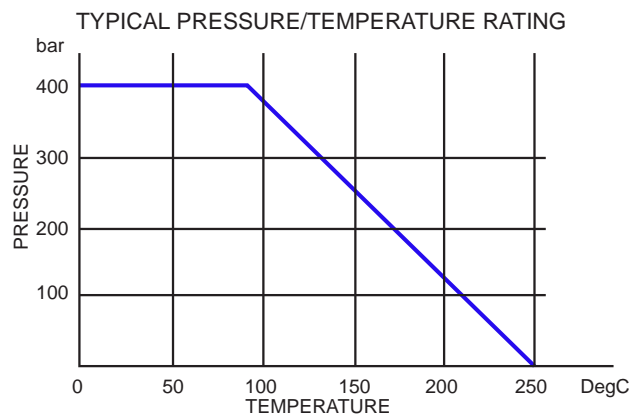

**STEWART-BUCHANAN GAUGES LTD**  
Sales Office & Manufacturing Facility,  
Burnside Industrial Estate, Kilsyth, Glasgow, G65 9JX, SCOTLAND  
Tel:- +44 (0)1236 821533  
Fax:- +44 (0)1236 824090  
E-Mail:- sales@stewarts-group.com  
Web Site:- www.stewarts-group.com