

(All components designed and manufactured by Stewarts)  
**Standard style**

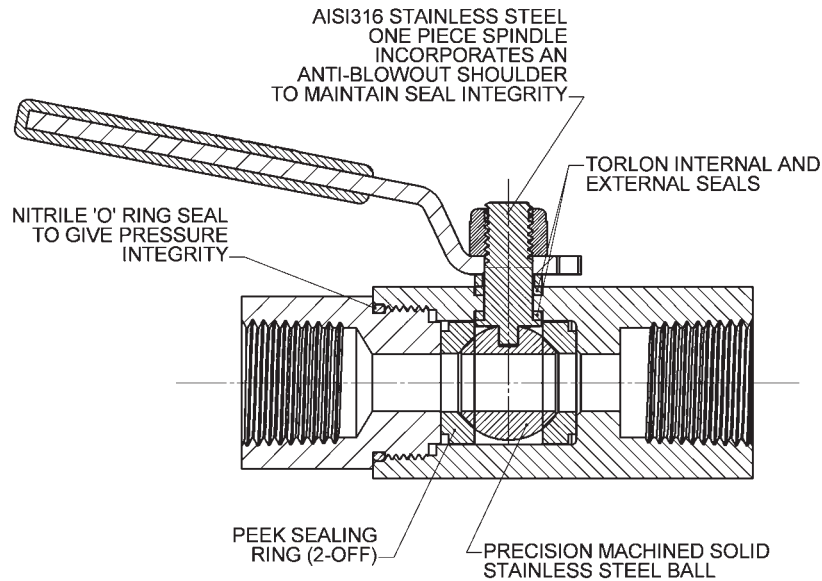

## OTHER FEATURES

- Hydrostatically tested to 1.5 times maximum working pressure.
- Available in a variety of materials, AISI 316 stainless steel, Monel etc.
- Has trace code on body and end connectors with material certificates available for all wetted parts on request.
- Can be supplied to NACE MR-01-75.
- Other seals available by arrangement.
- 90 Deg turn precision ball with 10mm diameter thru bore allowing rodding through bi-directional flow.

## PRESSURE / TEMPERATURE RATINGS

