

## The Pressure Gauge For Shock and Surge Problems

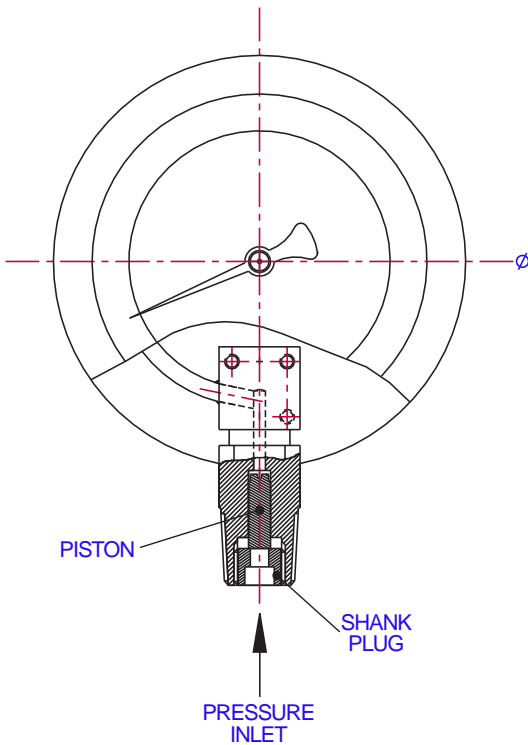

Model - 632 Snubbagaug<sup>®</sup> (100mm, 4" Direct Mounted (Standard))  
The "Snubbagaug" is available in all our applicable configurations,  
Please contact our sales advisors for technical assistance.

*Snubbagaug*<sup>®</sup> 'SNUBBAGAUG<sup>®</sup>' is a registered trade mark of Stewarts. A special machined piston which has been installed in the socket of the pressure gauge gives perfect resistance to shocks and surges. It does not interfere with the safety features of the instrument.

In combination with the 'VIBRAGAUG<sup>®</sup>' the gauge will give excellent performance where, vibrations, shocks, and surges would normally shorten the life of a pressure gauge.

'SNUBBAGAUG<sup>®</sup>' has undergone rigorous testing.

Gauges are supplied with 4 different pistons marked (01,02,03,04,) each having different diameters, to ensure desirable elasticity. These are intended for use in the following applications;

- 01-Light gases
- 02-Air / Steam
- 03-Water
- 04-Light Oil

Changing pistons to secure the best results is a simple matter. This is formulated by the removal and replacement of the shank plug.

**It should be noted that the piston size will depend on the operating temperature and actual medium being used. Therefore the above is intended as a guide only.**

As a standard the gauge will be fitted with piston type 02.

Note:- To remove the piston.

For taper thread connections : Turn shank plug anti-clockwise.

For parallel thread connections : Turn shank plug clockwise

When refitting or changing the piston apply thread lock to shank plug threads (e.g Knipping VC<sup>®</sup>3)

We manufacture a wide range of instruments to customer's special requirements  
We shall be pleased to discuss and advise on your specifications.

Specifications and dimensions given in this leaflet represent the state of engineering at the time of printing.  
Engineering modifications may take place without prior notice.

**STEWART-BUCHANAN GAUGES LTD**  
Sales Office & Manufacturing Facility.  
Burnside Industrial Estate, Kilsyth, Glasgow, G65 9JX, SCOTLAND  
Tel:- +44 (0)1236 821533  
Fax:- +44 (0)1236 824090  
E-Mail:- sales@stewarts-group.com  
Web Site:- www.stewarts-group.com