

- Monoflange gives compactability and weight saving.
- Materials: 316 St/St-Monel etc.
- Has trace code, and body with material certificates available for all wetted parts on request.

How To Order

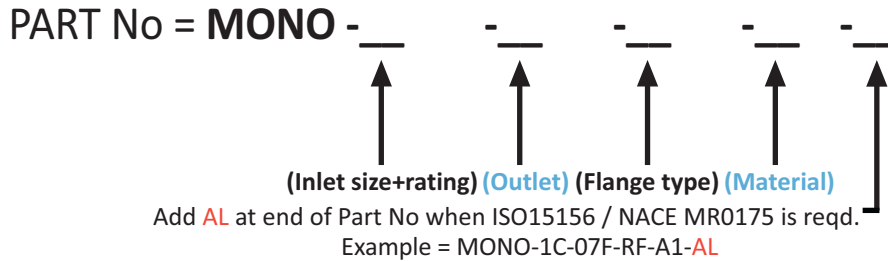

Inlet Size	Rating	Outlet Codes
1 = 1/2" (DN15)	A = 150 CLASS	03F = 1/4" NPT
2 = 3/4" (DN20)	B = 300 CLASS	05F = 3/8" NPT
3 = 1" (DN25)	C = 600 CLASS	07F = 1/2" NPT
4 = 1.5" (DN40)	D = 900 CLASS	04F = 1/4" BSPP
5 = 2" (DN50)	E = 1500 CLASS	06F = 3/8" BSPP
6 = 2.5" (DN65)	F = 2500 CLASS	08F = 1/2" BSPP
7 = 3" (DN80)	G = PN2.5 Bar	13F = 1/4" BSPTaper
8 = 4" (DN100)	H = PN6 Bar	14F = 3/8" BSPTaper
	J = PN10 Bar	15F = 1/2" BSPTaper
	K = PN16 Bar	Integral SWIVEMAS® connections to Stewarts Pressure Gauge available.
	L = PN25 Bar	
	M = PN40 Bar	
	N = PN63 Bar	

Flange type	Material Codes
RF = Raised Face	AI = AISI 316 S/S
RTJ = Ring Type Joint	MO = MONEL
	HA = HASTELLOY C276
	IN = INCOLOY 825
	DU = DUPLEX UNS S31803
	SD = SUPER DUPLEX S32760
	TI = TITANIUM
	HC = HASTELLOY C22
	IL = INCONEL 625

[View Page-2 for Dimensions Details](#)

Safety, Quality, Reliability

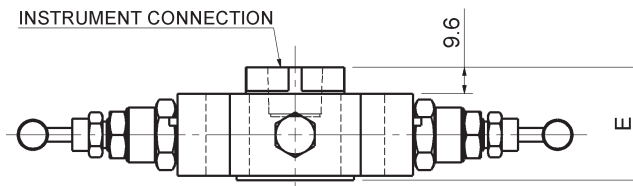
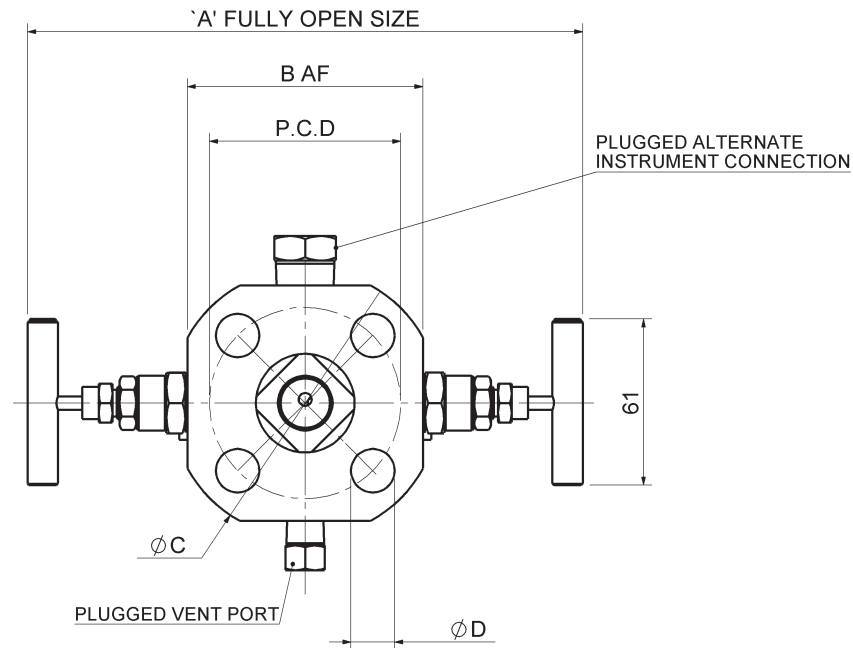

Flange Size	A	B	C	D	E	No of Holes	Holes P.C.D
1/2" ANSI 150lbs Raised Face	196	80	89	16	41	4	60.3
1/2" ANSI 300lbs Raised Face	202	86	95.2	15.9	41	4	66.7
1/2" ANSI 600lbs Raised Face	202	86	95.2	15.9	46	4	66.7
1/2" ANSI 900lbs Raised Face	228	110	120	22.2	46	4	82.5
3/4" ANSI 150lbs Raised Face	204	86	98.4	15.9	41	4	69.8
3/4" ANSI 300lbs Raised Face	223	105	117	19	41	4	82.5
3/4" ANSI 600lbs Raised Face	228	110	117	19	46	4	82.5
1" ANSI 150lbs Raised Face	216	100	108	15.9	41	4	79.4
1" ANSI 300lbs Raised Face	232	116	123.9	19	41	4	88.9
1" ANSI 600lbs Raised Face	232	116	124	19	46	4	88.9
1" ANSI 900 lbs Raised Face	254	136	149	25.4	46	4	101.6
1.5" ANSI 150lbs Raised Face	234	116	127	15	41	4	98.4
1.5" ANSI 300lbs Raised Face	254	136	155.6	22.2	41	4	114.3
1.5" ANSI 600lbs Raised Face	254	136	155.6	22.2	46	4	114.3
2" ANSI 150lbs Raised Face	252	136	152.4	19	41	4	120.6
2" ANSI 300lbs Raised Face	274	156	165.1	19	41	8	127
2" ANSI 600lbs Raised Face	274	156	165.1	19	46	8	127
2" ANSI 900lbs Raised Face	321	205	215.9	25.4	61.4	4	165.1