

Models- 975, 2050 Stainless Steel Thermometers

Temperature element

- (a) Bi-Metal System
- (b) Inert Gas System

Case

AISI 304 Stainless Steel
Bezel Stainless Steel (Bayonet type).
Weatherproof Construction

Dial

White Aluminium (Black Printing)

Pointer

Black Aluminium

Window

Sheet Glass

Standard Size

100, 125, 150mm

Accuracy class

1% Gas filled
1.5% Bi-Metal

Scale Range

Bi-Metal - 50 up to 600 deg C.
Gas Filled - 100 up to 650deg C.
See standard scale range data sheet.

Stem

Stainless Steel.

Stem Dia

Bi-Metal - 6, 8,10, or 12mm.
G.F - 6,8,10,12, or 12.7 mm.

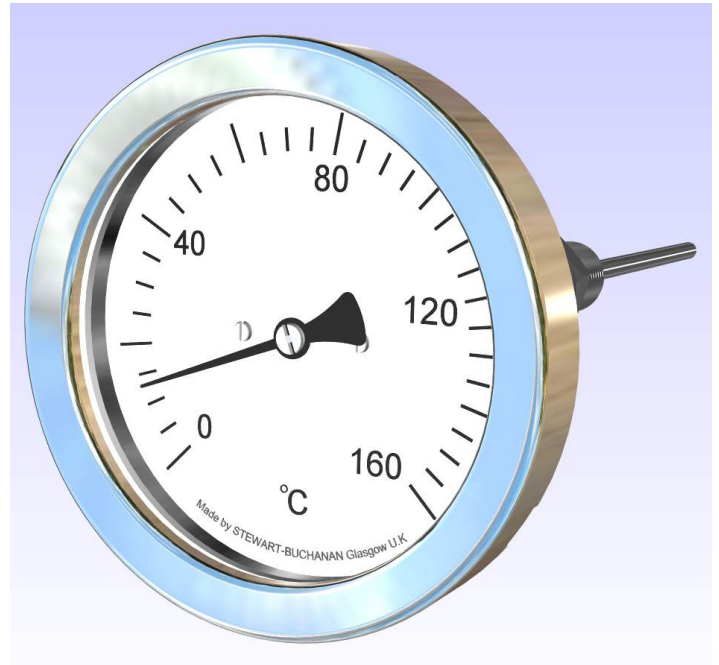

Model - 2050

Optional extras

AISI 316 Stainless Steel Case.
Slot adjustable pointer / Black Finish.
Window laminated Safety Glass / Perspex.
Thermowells per DIN or to user specification.
Additional Variations: on request.

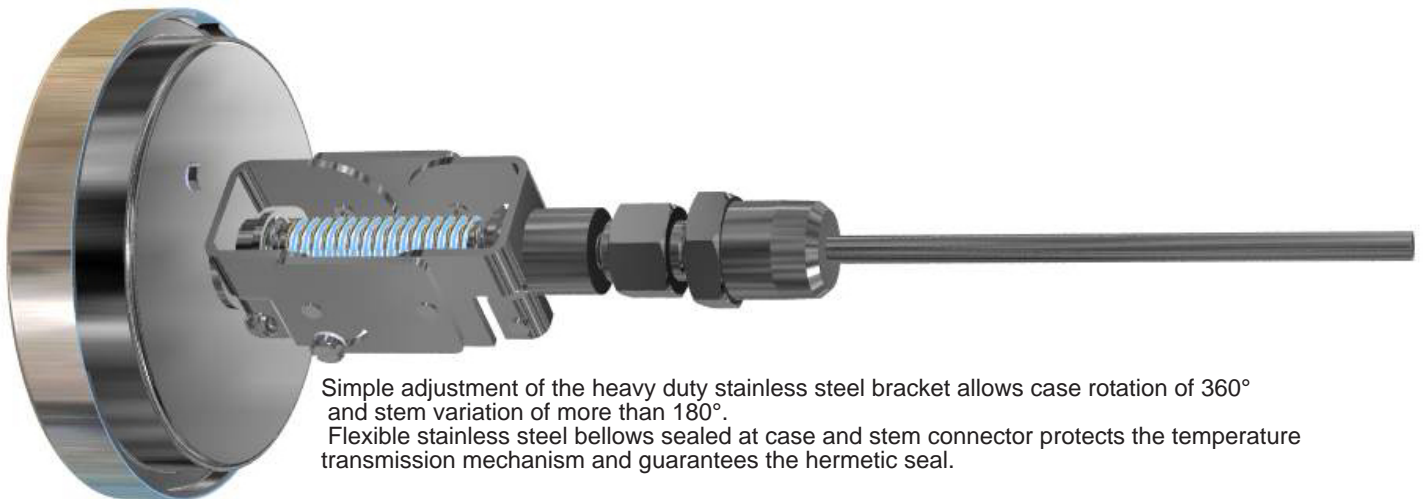

Simple adjustment of the heavy duty stainless steel bracket allows case rotation of 360° and stem variation of more than 180°. Flexible stainless steel bellows sealed at case and stem connector protects the temperature transmission mechanism and guarantees the hermetic seal.

Models- 975, 2050 Stainless Steel Thermometers

Gas Filled System
Model - 975

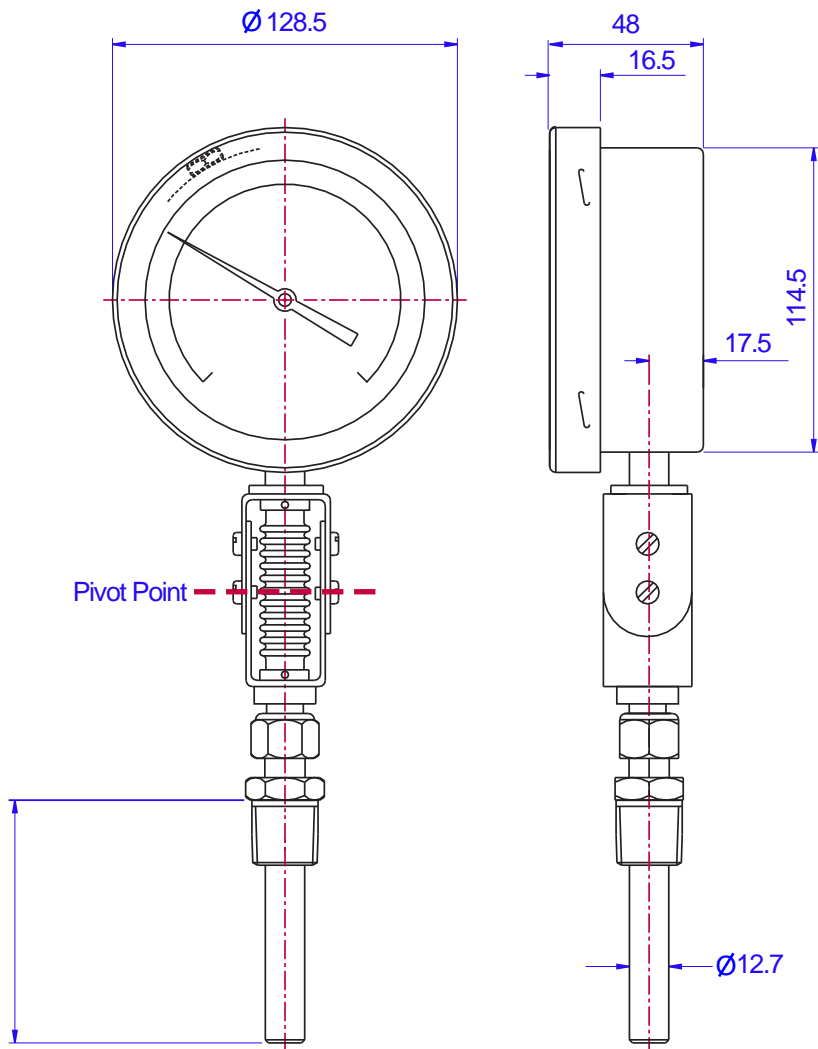

Bi-Metal System
Model - 2050

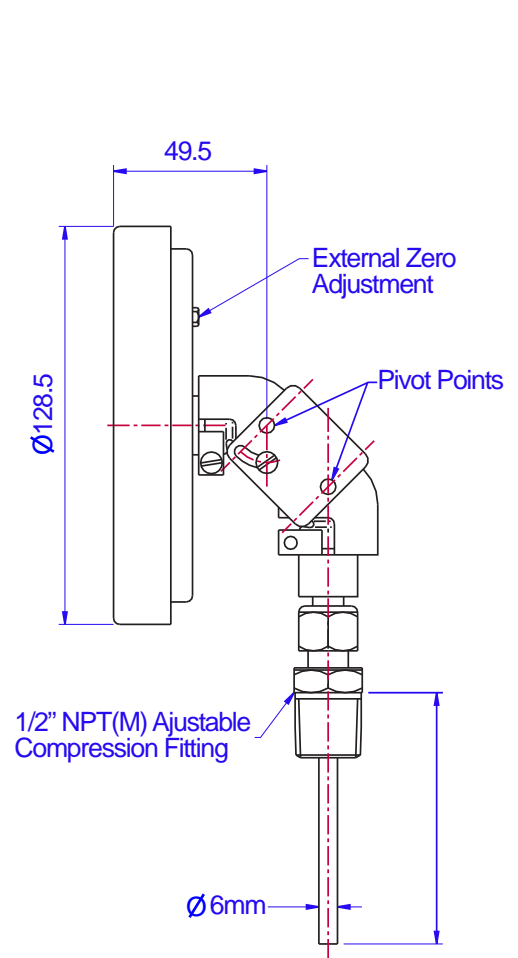

We manufacture a wide range of instruments to customer's special requirements
We shall be pleased to discuss and advise on your specifications.

Specifications and dimensions given in this leaflet represent the state of engineering at the time of printing.
Engineering modifications may take place without prior notice.